



# **2018 LIPTON CHALLENGE CUP**

## **NOTICE OF CONTEST & SAILING INSTRUCTIONS**

Notice is hereby given that the Royal Cape Yacht Club (RCYC), as holders of this Cup at present, have been called upon by the Lipton Trustees to prepare to defend the Cup against all challengers in a Contest to be held in terms of this Notice. This will be the 66th defense of the Lipton Challenge Cup in its 109 year history. Eligible Yacht Clubs in Southern Africa are invited to challenge the RCYC for the Cup by entering a yacht crewed by their club members in the Contest outlined below.

### **1. DATES**

Friday 6 July 2018 to Friday 13 July 2018, both dates inclusive.

### **2. VENUE**

Point Yacht Club (PYC), Durban, Kwa-Zulu Natal. Racing will take place offshore in the vicinity of The Port of Durban.

### **3. ORGANISING AUTHORITY**

The Organising Authority will be the PYC, under the authority of the RCYC Lipton Trustees (Lipton Trustees).

### **4. MANAGEMENT**

The Contest shall be under the management of the 2018 Lipton Challenge Cup Race Committee (Race Committee) from 14h00 on Saturday 7th July 2018.

The Race Committee shall consist of three members nominated by the PYC Organising Committee, and one member nominated by the Lipton Trustees, one of whom shall act as Chairperson, as well as one nominated representative of each competing Club.

In the event of a member representing more than one Club, that member may nevertheless only cast one vote in any ballot. A simple majority of votes shall carry any motion.

The Race Committee shall have full powers to decide all matters relating to the Contest except in the matter of protests and requests for redress, which shall be decided by the Protest Committee.

### **5. CLASS OF BOAT**

In terms of the Lipton Challenge Cup Deed of Gift, as amended (Deed of Gift), this Contest shall be sailed in boats of the L26 Class.

## **6. RULES**

The Contest will be governed by:

1. The rules as defined in the Racing Rules of Sailing [RRS]
2. The Equipment Rules of Sailing
3. The L26 Class Rules as at 31<sup>st</sup> May 2018.

Where relevant, precedence shall be given in the reverse order of listing. In the event of contradictions, a determination will be made by the Protest Committee.

## **7. ELIGIBILITY**

7.1. This Contest is open to:

- 7.1.1. All clubs affiliated to and in good standing with South African Sailing (SAS)
- 7.1.2. Clubs in Namibia as far north as Walvis Bay affiliated to and in good standing with the Namibia Sailing Association.
- 7.1.3. Clubs in Mozambique as far north as Beira affiliated to and in good standing with the Federação Moçambicana de la Vela e Canoagem.
- 7.1.4. Clubs in Botswana affiliated to and in good standing with the Botswana Yacht Racing Association.

Only one entry will be accepted from any one Club.

7.2. Competitors shall be eligible only if they are:

- 7.2.1. Bona fide members, in good standing, of the Club they will represent in this Contest.
- 7.2.2. Members of SAS, or of their equivalent National Authority as required by that Authority.

7.3. A boat shall be eligible to compete only if:

- 7.3.1. She is owned by or on charter to or on loan to a Member and/or Members of a Club affiliated to SAS or relevant National Authority.
- 7.3.2. Her Owner and Skipper are both members in good standing of the L26 Class Owners' Association.
- 7.3.3. She holds a valid L26 Class Measurement Certificate issued or accepted by SAS or relevant National Authority, the number of which shall be stated on the entry form. A copy of the certificate shall be submitted with the entry form and the original thereof presented at Registration.
- 7.3.4. A member of the Race Committee has been nominated to act on her behalf and on behalf of her Club of Representation. Such nominees shall not be members of the crew of any competing boat.

## **8. ENTRIES**

Entries must be completed on the attached official entry form and submitted together with the required entry fee and crew list to The Secretary, Lipton Trustees at the address below, to be received by no later than 17h00 on Friday 8th June 2018. Acceptance of all entries will be subject to the approval of the Lipton Trustees.

IN TERMS OF THE DEED OF GIFT, LATE ENTRIES ARE NOT PERMITTED.

An Entry Fee of R4750 (four thousand seven hundred and fifty rand) inclusive of VAT must accompany the Formal Notice of Entry.

THE ENTRY FEE IS NOT REFUNDABLE.

The address for entries is:

<u>Postal</u>	<u>Street</u>	<u>Telecommunications</u>
PO Box 772	Duncan Road	Tel: +27 (21) 421 1354
Cape Town	Table Bay Harbour	Fax: +27 (21) 421 6028
8000	8001	e-mail:sailadmin@rcyc.co.za

Office hours: 08h00 to 17h00 on weekdays and 10h00 to 13h00 on weekends.

## **9. PAYMENT OF ENTRY FEES**

The entry fee should be paid directly to Royal Cape Yacht Club, by EFT (electronic funds transfer) in to the bank account listed below, and a copy of the proof of payment to be emailed, along with the Formal Notice of Entry, to [sailadmin@rcyc.co.za](mailto:sailadmin@rcyc.co.za). Please ensure that the payment reference is the name of the club of entry.

Bank Account details

Account name: Royal Cape Yacht Club  
Account Type: Current  
Bank: FNB Commercial  
Branch code: 25 06 55  
Account No: 50050045316

## **10. REGISTRATION**

Entries shall be confirmed by registration with the Contest Secretary at the venue between 09h00 and 17h00 on Friday 6 July 2018 or between 08h00 and 12h00 on Saturday 7 July 2018. The following documents shall be completed as required by the provisions of this Notice, and presented at Registration:

1. Final Crew List and Declaration, together with current Club Membership Cards of the Club of Representation as well as valid Membership Cards of their respective National Authority per item 7. Eligibility (above) for each member of the crew or, where such Membership Cards are not available, an official letter from the Club of Representation, signed by the commodore, confirming that the skipper and crew are members of that club and comply with item 7.2.1 (above) and have each paid their current National Authority subscriptions.
2. Current Measurement Certificate for the boat
3. Sail Measurement Verification Declaration
4. Measurement and Safety Declaration
5. Safety Check List (signed by a Scrutineer)
6. Crew Weight Declaration
7. Proof of Insurance

Failure to do so before the close of registration at noon on Saturday 7 July 2018 may result in non-acceptance of the entry at the sole discretion of the Race Committee.

## **11. CREW WEIGHT AND SUBSTITUTION**

The maximum permitted total weight of all crew members (dressed in a minimum of normally acceptable swimwear) shall not exceed 420kg. Crew members are required to weigh in by no later than 12h00 on Saturday 7 July 2018, and the Crew Weight Declaration form shall be completed. Failure to do so may result in non-acceptance of the entry at the sole discretion of the Race Committee.

All boats whose crew meet the requirements at the official weigh-in prior to the Contest, or at an official weigh-in after a crew change during the Contest, will be deemed to have satisfied L26 Class Rule 7.2 for the duration of the Contest.

The substitution of one crew member, including the Skipper, shall be permitted once during the Contest and this substitution shall be notified in writing to the Race Committee. Thereafter, no substitution shall be permitted without the prior written permission of the Race Committee. Only in exceptional circumstances of serious illness, injury or of a personal nature will the Race Committee allow such further substitutions. In the event of such substitution or substitutions, in terms of the above, the new crew member shall be weighed to ensure that the total crew weight remains within the maximum limit.

## **12. SCRUTINY OF EQUIPMENT**

It shall be the responsibility of the Skipper and an appointed crew member to inspect their boat for compliance with the Safety Requirements of this Contest and the rules of the L26 Class. The official Measurement and Safety Declaration form shall be certified by the Skipper and the appointed crew member.

All boats will be weighed to ensure compliance in terms of the minimum weight requirements of the Class Rules.

At the request of the Organising Committee or the Race Committee, inspections, including boat weighing, may be carried out at any time between **09h00 on Friday 6 July 2018 and the time limit for lodging protests after the last race of the Contest**. The Skipper and the appointed crew member must make themselves available and be present during the inspection of the boat.

One suit of sails together with the Sail Measurement Verification Declaration, duly completed, shall be presented to a Scrutineer for verification and stamping before 12h00 on Saturday 7 July 2018. The same sails shall be carried for the duration of the Contest and may only be replaced after written permission of the Race Committee has been obtained. Only in exceptional circumstances will the Race Committee grant such permission.

Unless she has obtained the prior written permission of the Race Committee to do so, a boat shall be subject to protest by the Race Committee if she fails to display her own number on her sails in accordance with the Class Rules. Only in exceptional circumstances will the Race



Committee grant such permission.

### **13. SCHEDULE OF RACES**

- 13.1. The intention is to hold six races over six days, commencing Sunday 8 July 2018. The scheduled time of the warning signal for each day of the Contest is 10h55.
- 13.2. The first three races will be sailed over the three Compulsory Courses specified in the third condition of the Deed of Gift. These are courses R, S & T in the diagram below. A maximum of three more races will be sailed over one or more of the courses in the diagram below.
- 13.3. Only one race shall be sailed each day unless:
  - 13.3.1. By the end of the second day of sailing (Monday 9 July 2018) none of the Compulsory Course races has been completed, or
  - 13.3.2. By the end of the third day of sailing (Tuesday 10 July 2018) none or only one of the Compulsory Course races has been completed.Under these circumstances up to two races over Compulsory Courses will be sailed on the remaining day or days until each of the remaining Compulsory Course races has been completed.  
An additional race shall not be sailed on the same day as a Compulsory Course race.
- 13.4. On Friday 13 July 2018 no warning signal shall be made after **14h55** unless by that time only two races have been completed.

### **14. COURSES**

- 14.1. The diagrams below show the courses, including the approximate angles between legs, the order in which marks are to be passed, and the side on which each mark is to be left.
- 14.2. **All Courses shall be a minimum of 12 nautical miles in length.**
- 14.3. No later than the warning signal the race committee signal boat will display the course to be sailed, the number of rounds, and the approximate compass bearing of the first leg.
- 14.4. If the letter L is displayed after the letter indicating the course to be sailed, the finish line will be at the last rounding mark of the course ie. Mark 4 in Course R, Mark 2 in Course S, and Mark 3 in Courses T and O. In this event, the mark in question will be moved by no more than the distance needed to make it the port-end buoy of the finish line.
- 14.5. If the race officer intends moving the course area prior to a start, the race committee signal boat will display flag L with a sound signal and move to the new area.

#### **Course Diagrams**

**COURSE "R"**: A rectangular course with either 1, 2, 3, or 4 rounds before the final windward leg.

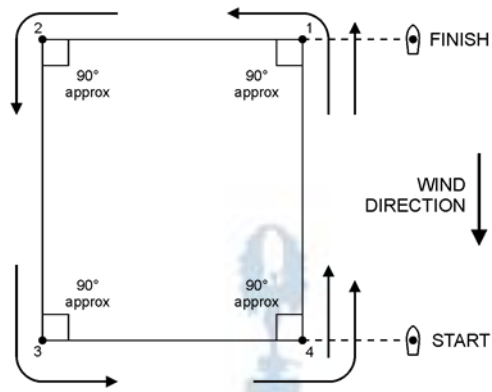

**COURSE "S"**: A windward-leeward course, with either 1, 2, 3 or 4 rounds before the final windward leg.

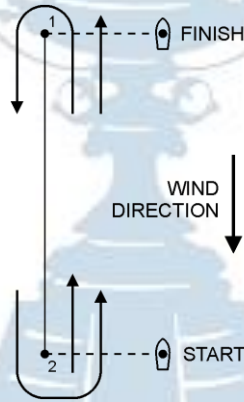

**COURSE "T"**: A triangular course, with either 1, 2, 3 or 4 rounds before the final windward leg.

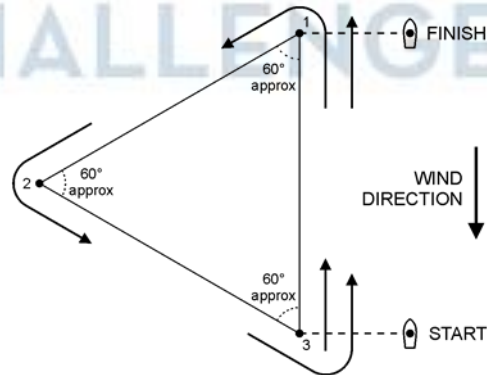

**COURSE "O"**: A combination course to be sailed as set out in the diagram below.

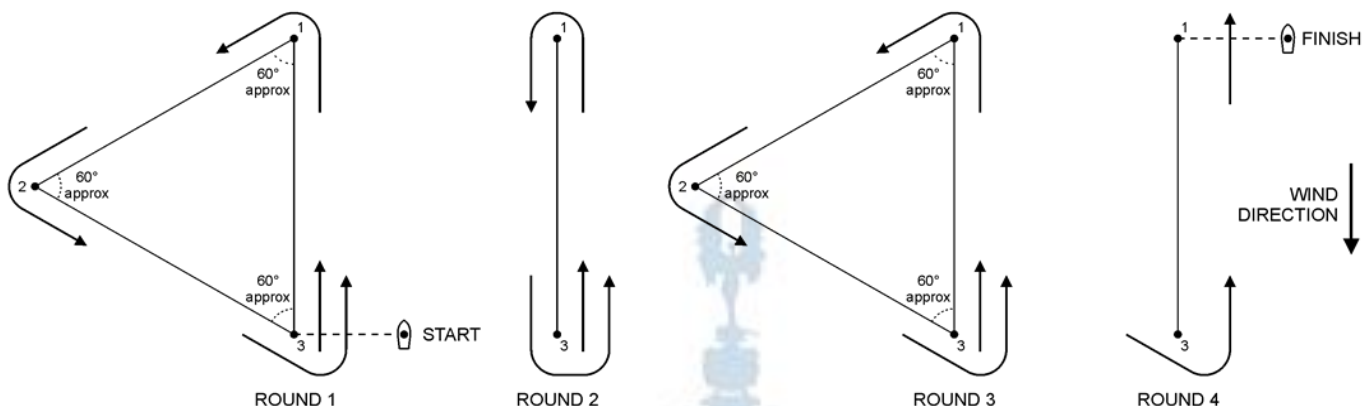

## **15. MARKS**

15.1. Marks 1, 2, 3 and 4 will be as described on the official notice board.

15.2. The starting and finishing marks will be the race committee signal boat flying the PYC burgee at the starboard end and a buoy at the port end.

## **16. CLASS FLAG**

The L26 class flag has a blue L26 class insignia on a pink background.

## **17. THE START**

17.1. The starting line will be between a staff displaying an orange flag on the race committee signal boat at the starboard end and the course side of the port-end starting mark.

17.2. When, after a postponement, it is the intention of the race officer to start a race soon, the orange starting line flag will be hoisted with a sound signal. This flag will be hoisted not less than 5 minutes before the warning signal.

## **18. CHANGE OF THE NEXT LEG OF THE COURSE**

To change the next leg of the course, the race committee will move the original mark (or the finish line) to a new position.

## **19. THE FINISH**

The finishing line will be between a staff displaying an orange flag on the race committee signal boat at the starboard end and the course side of the port-end mark.

## **20. TIME LIMITS**

20.1. The time limit for each race shall be the earlier of four hours after the start or 17h00.

20.2. Boats starting later than 15 minutes after the starting signal will be scored Did Not Start without a hearing. This changes RRS A4 and A5.

20.3. Boats failing to finish within 30 minutes after the first boat sails the course and finishes will be scored Did Not Finish without a hearing. This changes RRS 35, A4 and A5.

## **21. NOTICE TO COMPETITORS**

Notices to competitors will be posted on the official notice board and the protest notice board located in the PYC clubhouse.

## **22. SIGNALS MADE AHORE**

22.1. Signals made ashore will be displayed from the mast in front of the clubhouse.

22.2. When Flag AP is displayed ashore “1 minute” is replaced by “not less than 90 minutes” in race signal AP.

## **23. CHANGES TO THE SAILING INSTRUCTIONS**

Any change to the sailing instructions will be posted before 09h00 on the day it will take effect, except that any change to the schedule of races will be posted by 20h00 on the day before it will take effect.

## **24. PENALTY SYSTEM**

24.1. RRS 44.3 (Scoring Penalty) will not apply.

24.2. The skipper of a boat that has taken one or more penalties, including retiring, under RRS 44.1 is required to sign a declaration to this effect on the form provided at the race office within the protest time limit.

24.3. Penalties for breaches of the L26 Class rules are at the discretion of the protest committee in terms of RRS 64.1.

24.4. For breaches of certain of the sailing instructions and certain provisions of the notice of contest the race committee may apply a standard penalty without a hearing. This changes RRS 63.1 and A5.

24.5. A list of these breaches and the associated standard penalties will be posted in Sailing Instructions Annexure A on the official notice board.

24.6. A boat that has been penalised with a standard penalty cannot be protested for the same incident by another boat, nor can another boat request redress for this race committee action. This changes RRS 60.1 and 63.1.

## **25. PROTESTS AND REQUESTS FOR REDRESS**

25.1. Protest forms will be available on the protest notice board. Protests and requests for redress or reopening shall be delivered there within the appropriate time limit.

25.2. The protest time limit is 90 minutes after the last boat has finished the last race of the day or the race committee signals no more racing today, whichever is the later.

25.3. Notices will be posted no later than 30 minutes after the protest time limit to inform competitors of hearings in which they are parties or named as witnesses.

25.4. Notices of protests by the race committee or protest committee will be posted on the official notice board to inform boats under RRS 61.1(b).



- 25.5. Protests will be heard at a place designated on the official notice board.
- 25.6. Any measurement protest lodged after the protest time limit at the end of the first day's racing shall be refused, unless it is based on facts which, in the opinion of the protest committee, could not have been ascertained readily by the protestor prior to that time and date. This does not apply to protests lodged by the scrutineers appointed by the sailing committee. This is a change to RRS 61.3.
- 25.7. Breaches of instructions 28, 30, 31, 32, 33, 34 & 36 will not be grounds for protest by a boat. This changes RRS 60.1(a). Penalties for these breaches may be less than disqualification if the protest committee so decides.
- 25.7.1. On the last scheduled day of racing, a request for reopening a hearing shall be delivered :Within the protest time limit if the requesting party was informed of the decision on the previous day;
- 25.7.2. No later than 30 minutes after the requesting party was informed of the decision on that day.  
This changes RRS 66.
- 25.8. On the last scheduled day of racing a request for redress based on a protest committee decision shall be delivered no later than 30 minutes after the decision was posted. This changes RRS 62.2.

## **26. SCORING**

- 26.1. Each boat's score in the contest shall be the total of her race scores, with no score excluded. This changes RRS A2.
- 26.2. Three races, one over each of the compulsory courses R, S and T, are required to be completed for the contest to stand.
- 26.3. If this has not been achieved by the end of racing on Friday 13 July 2018, the contest shall be abandoned and the Lipton Challenge Cup remains with the defenders until the next challenge.

## **27. SAFETY EQUIPMENT & REGULATIONS**

All boats shall carry the mandatory equipment prescribed in Rule 6 of the Rules of the L26 Class throughout the Contest.

- 27.1. Before leaving shore to race on each scheduled racing day a crew member from each boat shall personally sign the check-out form at the race office.
- 27.2. Boats not leaving the harbour for a scheduled race shall promptly notify the race committee.
- 27.3. Boats retiring from racing shall notify the race committee before leaving the racing area or, if this is not possible, shall notify the race office by signing the retirement declaration sheet as soon as possible after returning to shore, but by no later than the protest time limit.
- 27.4. Within 30 minutes after returning ashore on each scheduled racing day a crew member from each boat shall personally sign the check-in form at the race office.
- 27.5. Boats shall keep clear of commercial traffic both within and beyond Durban harbour.

## **28. EQUIPMENT AND MEASUREMENT CHECKS**

- 28.1. A boat or equipment may be inspected at any time for compliance with the L26 class rules and Notice of Contest and Sailing Instructions.
- 28.2. This may involve a sailing committee scrutineer boarding a boat (a) prior to a start, but not within 15 minutes of a warning signal, or (b) after a boat has finished.
- 28.3. After finishing a boat so instructed by a technical committee representative shall proceed promptly to a designated area for inspection.
- 28.4. Inspections shall be carried out in accordance with the protocol outlined in Sailing Instructions Annexure B on the official notice board.

## **29. HAULING OUT RESTRICTIONS**

Boats shall be afloat in the Durban Marina not later than 1200 on Saturday 7 July 2018 and shall not be hauled out until after the finish of the last race on Friday 13 July 2018 except with, and according to the terms of, prior written permission of the race committee.

## **30. COMMUNICATIONS AND DURBAN HARBOUR REQUIREMENTS**

Each boat shall carry a VHF Radio, which shall be maintained in good working order throughout the Contest and which shall be capable of transmitting and receiving channels 06, 09, 16, and 68. All boats shall monitor VHF channel 09, Durban Port Control, while under way within the harbour. All boats shall stand by on Channel 06 after leaving and until re-entering the harbour, unless otherwise advised at the daily Race Committee meeting. If Channel 06 is too busy or jammed the Race Officer may change to Channel 68, or as advised.

Except in an emergency, a boat that is racing shall not make voice or data transmissions and shall not receive voice or data communication that is not available to all boats.

If reasonably possible, the Race Officer will announce over the VHF channel in use, the bow letters or sail numbers of any recalled boats as soon as possible after the start. If no boats are recalled he will, if reasonable possible, call "All clear" as soon as possible after the start.

The timing of this call, the sequence of the boats called, the audibility of the message, or the lack of any such call shall not be grounds for redress. This changes RRS 60.1(b).

A boat may request the Race Officer to repeat the call, and he will do so if reasonably possible. A failure to repeat the call will not be grounds for redress. This changes RRS 41 and 60.1(b).

## **31. LEADER IDENTIFICATION**

- 31.1. Boats lying 1<sup>st</sup>, 2<sup>nd</sup> and 3<sup>rd</sup> overall after each day's racing are required to display yellow, blue or red discs respectively on their mainsails during the following day's racing.
- 31.2. In the event of outstanding protests that might affect the first three positions overall, the issue of discs on that day will be based on the provisional results at the time.
- 31.3. The race committee will provide the sticky-back discs not later than 09h00 each day.
- 31.4. The discs shall be positioned centrally, 100mm to 200mm below the port side sail number, back to back on both sides of the sail.

31.5. For the first race of the contest the boat representing the defending club will display yellow discs.

## **32. BOW LETTERS AND ADVERTISING**

32.1. A pair of bow letter decals will be provided to each boat and shall be fitted as specified in Sailing Instructions Annexure C on the official notice board.

32.2. Advertising is permitted subject to the limitations of ISAF Regulation 20. If secured, the event Sponsor may require advertising material to be displayed on competing boats in accordance with Sub-regulation 20.4.

32.3. Failure to display the bow letters and advertising decal (if provided) in the required position throughout the contest may result in a penalty being imposed by the protest committee.

## **33. OFFICIAL BOATS**

Official boats will display **yellow** identification flags. Media boats will display **pink** identification flags.

## **34. SUPPORT BOATS & SPECTATOR BOATS**

34.1. Support boats shall display conspicuously a white flag and the burgee/s of the respective club/s they are supporting.

34.2. Unless directed by a race official or attending to a boat in distress, support boats and spectator boats shall not come within 100m of a boat racing.

## **35. TRASH DISPOSAL**

35.1. Competitors' attention is drawn to RRS 55.

35.2. Trash may be placed aboard official boats or support boats.

## **36. ISAF ANTI-DOPING CODE**

Testing of competitors may be conducted in terms of the ISAF anti-doping code contained in Regulation 21. Therapeutic use in terms of Sub-regulation 21.4.3(a) shall be submitted at Registration in a sealed envelope, addressed to the SAS Medical Officer.

## **37. TROPHIES AND PRIZES**

Trophies will be awarded as per the attached List of Trophies. Additional prizes may be awarded at the discretion of the Organising Committee and the Lipton Trustees.

## **38. DISCLAIMER OF LIABILITY**

Competitors participate in this Contest entirely at their own risk. Refer RRS 4, Decision to Race. The Organising Authority including all persons, organisations and their agents concerned with the conduct of this Contest will not accept any liability for material damage or personal injury or death sustained in conjunction with or prior to, during, or after the Contest, however arising.

All competitors shall sign the Declaration acknowledging the disclaimer of liability which is included on the Crew List Form. In the event that the signatory of the Declaration is younger than 18 years of age it shall be counter-signed by their parent or guardian.

### **39. INSURANCE**

The Organising Authority requires that each entry carries adequate insurance to the value of not less than R2.5m (two million, five hundred thousand rand) to cover against any eventualities and in particular against Public Liability and Third Party claims.

### **40. FURTHER INFORMATION**

For further information please contact the Point Yacht Club Sailing Office on 031 301 4787 or [sailing@pyc.co.za](mailto:sailing@pyc.co.za)

A copy of the Conditions and Rules of the Deed of Gift is available on the Lipton Cup website [www.liptoncup.com](http://www.liptoncup.com)

The Equipment Rules of Sailing can be found on the World Sailing (previously ISAF) website <http://www.sailing.org/isaf/index.php> under the heading DOCUMENTS & RULES.

A copy of the current L26 Class Rules is available on the Class website: <http://www.l26.co.za/>, under the heading L26 CLASS.

This document (Notice of Contest and Sailing Instructions) incorporates the Notice of Race as required in terms of the Racing Rules of Sailing.

Any clubs, L26 owners or L26 sailors who have queries regarding the Class Rules or interpretation of these Rules are urged to contact the L26 Class Technical Committee via Michael Surgeson at [michael.surgeson@bcx.co.za](mailto:michael.surgeson@bcx.co.za).

***By order and on behalf of the Royal Cape Yacht Club Lipton Trustees.***



**David Hudson**  
**Chair - Lipton Trustees**